

GENERAL NOTES:
 UNIT INSTALLS ON FINISH FLOOR. UNDERGROUND WIRING CONDUIT REQUIRED. OPTIONAL PLATFORM AVAILABLE. FLOOR MUST BE DEAD LEVEL. UNIT IS FREE STANDING - NO VERTICAL STRUCTURAL SUPPORT REQUIRED.

ELECTRICAL NOTES:
 POWER SERVICE REQUIRED: 110VAC OR 220VAC (1) PHASE 60HZ, 15A, NEUTRAL, GROUND. AUTHORIZATION REQUIRES DRY CONTACT FROM ACCESS CONTROL.

ALL CONDUIT BY OTHERS.

CODED NOTES:
 1. CABINET - #4 STAINLESS STEEL, ALTERNATE P.C. COLORS AVAILABLE
 2. TOP - BLACK TEMPERED GLASS
 3. AUTHORIZATION LIGHT / CARD READER LOCATION
 MAX CARD READER SIZE: 3.15"W X 5.11"L X 2.07"H OR METRIC (80mm)W X (130mm)H X (51mm)H
 4. FRONT COVER - BLACK TEMPERED GLASS
 5. CLEAR TEMPERED GLASS BARRIER

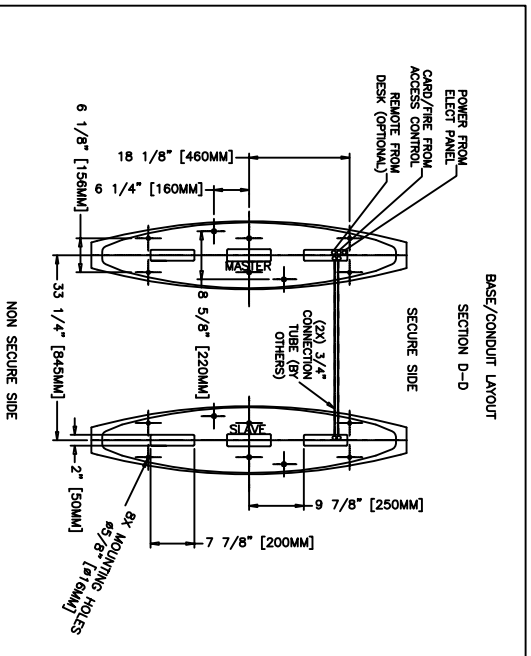
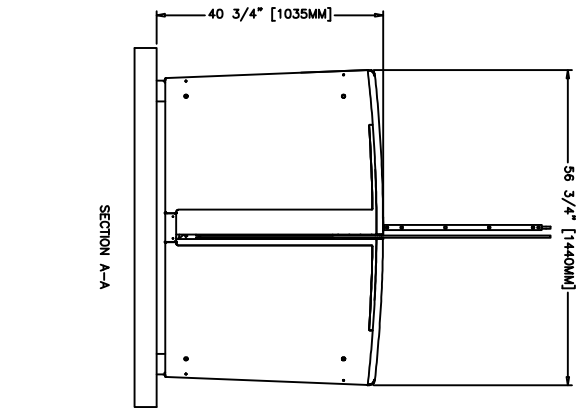
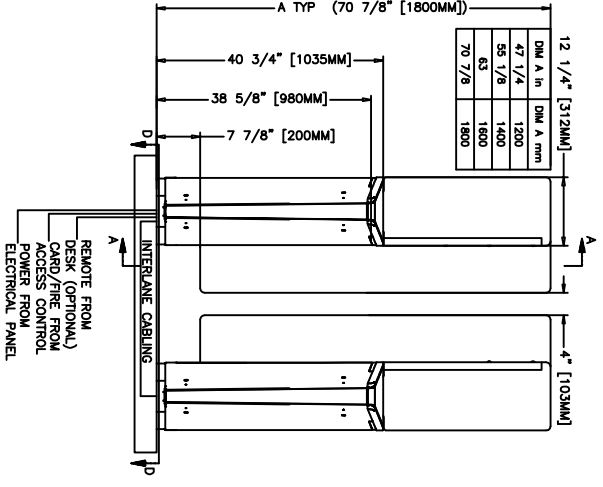

SPEEDLANE SLIDE TALL: 1 LANE - 1 STD TALL

Project: _____
 Job #: _____
 Rev: B
 Rev Date: 11/21/16

Customer: _____
 Contractor: _____
 Architect: _____

By: AA

Dwg #:



402 McKinney PKWY, Lillington, NC 27546 • (910) 814-3800 © BOON EDAM