

GENERAL NOTES:

- UNIT INSTALLS ON FINISH FLOOR.
- FLOOR MUST BE DEAD LEVEL (MAX 3/16" RISE) THROUGHOUT FOOTPRINT.
- UNDERGROUND WIRING CONDUIT REQUIRED.
- OPTIONAL PLATFORM AVAILABLE.
- UNIT IS FREE STANDING – NO VERTICAL STRUCTURAL SUPPORT REQUIRED. ANCHORING TO FLOOR IS REQUIRED.
- ADHERE TO LOCAL CODES DURING INSTALLATION.

CODED NOTES:

1. CABINET – #4 STAINLESS STEEL
2. TOP – BLACK TEMPERED GLASS: 1/4"[6MM] THK
3. CARD READER + AUTHORIZATION LIGHT LOCATION.
MAX CARD READER SIZE:
2.16"[55mm]W X 5.11"[130MM]L X 2.0"[51mm]H
4. FRONT COVER – BLACK TEMPERED GLASS: 1/4"[6MM] THK
5. CLEAR TEMPERED GLASS BARRIER: 3/8"[10MM] THK
6. CARD ENTRY / CARD EXIT

ELECTRICAL NOTES:

- REFER TO BOON EDAM INSTALLATION SITE REQUIREMENTS SHEET
- ALL CONDUIT BY OTHERS.

MAINS VOLTAGE OPTIONS:

- 110VAC, 60HZ, SINGLE PHASE (L1,N,PE) 20AMP BREAKER
- 220VAC, 60HZ, DUAL PHASE (L1,L2,PE) 20AMP BREAKER

LISTINGS/RATINGS:

- UL 2593, UL325, CSA C22.2 NO. 247-14
- 110V, 60HZ, 1.5A
- 220V, 60HZ, 0.8A

ACCESS CONTROL SIGNALS:

- INPUTS: SEE MANUAL. CARD READ SIGNALS: N/O, 1 SECOND PULSE.
- OUTPUTS: CONFIGURABLE FOR NORMALLY OPEN OR NORMALLY CLOSED. (SEE MANUAL)
- FIRE ALARM: NORMALLY CLOSED DRY CONTACT, SEPERATE SIGNAL TO EACH MASTER (CANNOT BE DAISY CHAINED)

BOONTOUCH REQUIRES:

- ONE (1) CAT 6 HOME RUN CABLE FROM BOONTOUCH CONTROL PANEL TO MASTER UNIT. BY OTHERS. FOR DETAILS SEE CONDUIT LAYOUT.
- ONE (1) ADDITIONAL CABLE BETWEEN EACH LANE. BY OTHERS.
- ONE (1) CABLE BETWEEN ARRAYS. BY OTHERS. FOR DETAILS SEE CONDUIT LAYOUT.
- MAX 6 LANES PER BOONTOUCH PANEL.

REV	DESCRIPTION	PAGE	DATE
C	SWING UPDATED TO 2.0	1 OF 3	8/7/20 AA
B	CHGD NOTE D & CONDUIT SIZE	1 OF 3	1/17/20 AA
A	CUTSHEET	1 OF 3	10/10/19 HM

REVISION LOG

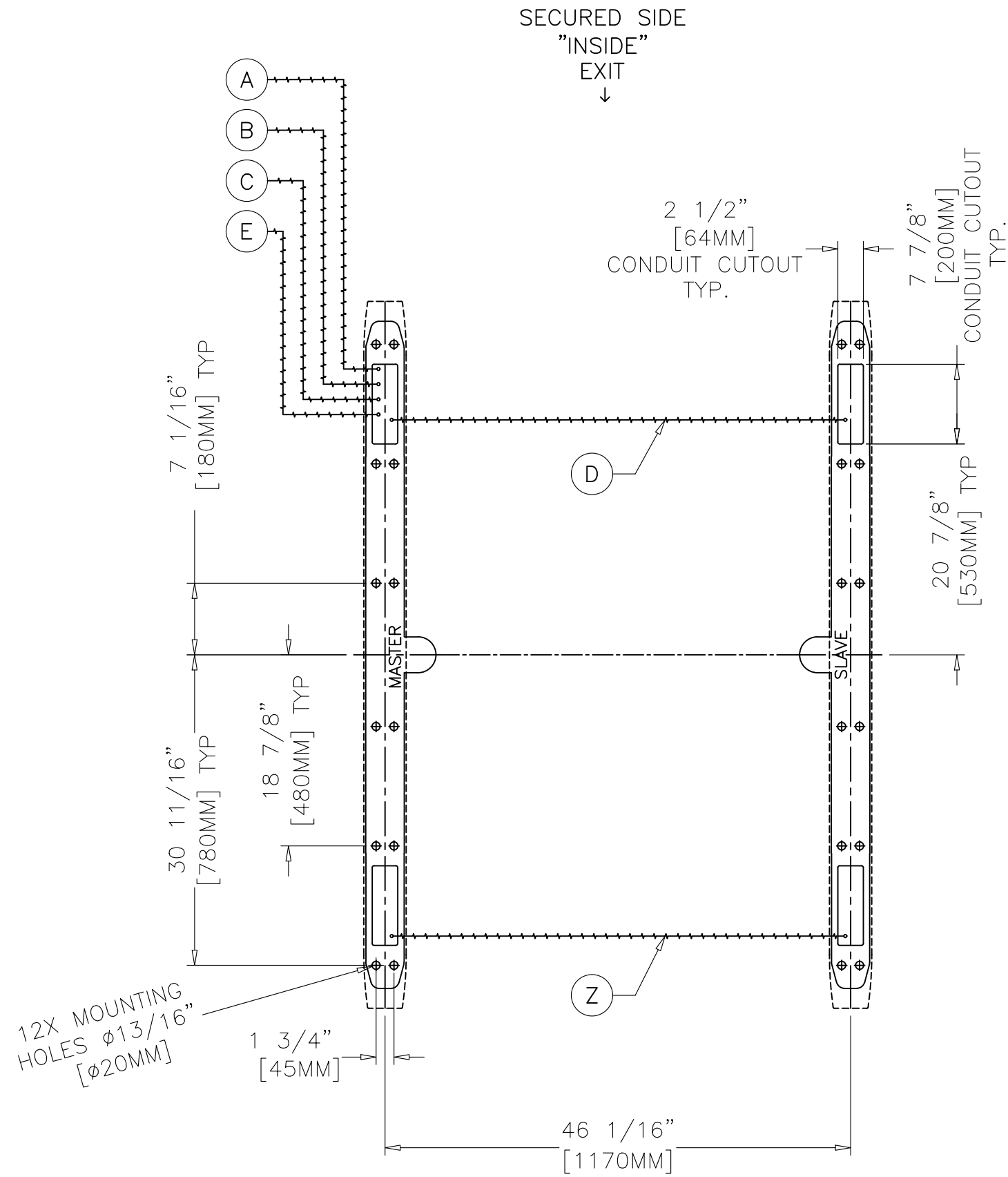

NON-SECURED SIDE
"OUTSIDE"
ENTRY
↑

GENERAL NOTES:

- UNIT INSTALLS ON FINISH FLOOR.
- FLOOR MUST BE DEAD LEVEL (MAX 3/16" RISE) THROUGHOUT FOOTPRINT.
- UNDERGROUND WIRING CONDUIT REQUIRED.
- OPTIONAL PLATFORM AVAILABLE.
- UNIT IS FREE STANDING – NO VERTICAL STRUCTURAL SUPPORT REQUIRED. ANCHORING TO FLOOR IS REQUIRED.
- ADHERE TO LOCAL CODES DURING INSTALLATION.

ELECTRICAL NOTES:

- REFER TO BOON EDAM INSTALLATION SITE REQUIREMENTS SHEET
- ALL CONDUIT BY OTHERS.

MAINS VOLTAGE OPTIONS:

- 110VAC, 60HZ, SINGLE PHASE (L1,N,PE) 20AMP BREAKER
- 220VAC, 60HZ, DUAL PHASE (L1,L2,PE) 20AMP BREAKER

LISTINGS/RATINGS:

- UL 2593, UL325, CSA C22.2 NO. 247-14
- 110V, 60HZ, 1.5A
- 220V, 60HZ, 0.8A

ACCESS CONTROL SIGNALS:

- INPUTS: SEE MANUAL. CARD READ SIGNALS: N/O, 1 SECOND PULSE.
- OUTPUTS: CONFIGURABLE FOR NORMALLY OPEN OR NORMALLY CLOSED. (SEE MANUAL).
- FIRE ALARM: NORMALLY CLOSED DRY CONTACT, SEPARATE SIGNAL TO EACH MASTER (CANNOT BE DAISY CHAINED).

SECURE SIDE ONLY:

- A – ONE CONDUIT FOR MAINS POWER PER MASTER CABINET. CAN ALSO BE DAISY CHAINED UP TO 6 MASTER CABINETS.
- B – ONE CONDUIT FOR 2 CONDUCTOR FIRE PER MASTER CABINET.
- C – ONE CONDUIT FOR ACS CABLE – MAX 1/0 28 CONDUCTOR.
- D – ONE 1" CONDUIT FOR BOON EDAM SUPPLIED INTERLANE CABLING ONLY :
 - ONE INTERLANE 3 CONDUCTOR POWER CABLE (+24VDC, 0VDC, GROUND).
 - ONE INTERLANE CAT 6 COMMUNICATION CABLE.
 - 12' USEABLE CABLE SUPPLIED.
- E – 1/2" X CAT 6 CABLE TO FIRST MASTER FROM BOONTOUCH CONTROL PANEL. BY OTHERS.
- F – 1/2" X CAT 6 CABLE BETWEEN MASTERS FOR BOONTOUCH DAISY CHAIN. BY OTHERS. MAX. 6 LANES PER BOONTOUCH PANEL.

NON-SECURE SIDE:

- Z – OPTIONAL LOCATION FOR LOW VOLTAGE CABLING

BOONTOUCH CAN CABLE DETAILS (FOR E, F CABLE RUNS):

- NUMBER OF WIRES: 4 OR 6 CAT 6
- TYPE: TWISTED PAIR
- CORE: 26 OR 28 AWG STRANDED OR TINSEL WIRE
- INSULATION DIAMETER: 0.89-0.99 MM [0.035-0.039"]
- MAXIMUM OVAL CABLE JACKET: 2.29x6.61MM [0.090x0.260"]
- MAXIMUM TOTAL CABLE LENGTH: 100M (325')
- CONNECTORS: RJ12

REV	DESCRIPTION	PAGE	DATE
C	SWING UPDATED TO 2.0	2 OF 3	8/7/20 AA
B	CHGD NOTE D & CONDUIT SIZE	2 OF 3	1/17/20 AA
A	CUTSHEET	2 OF 3	10/10/19 HM

REVISION LOG

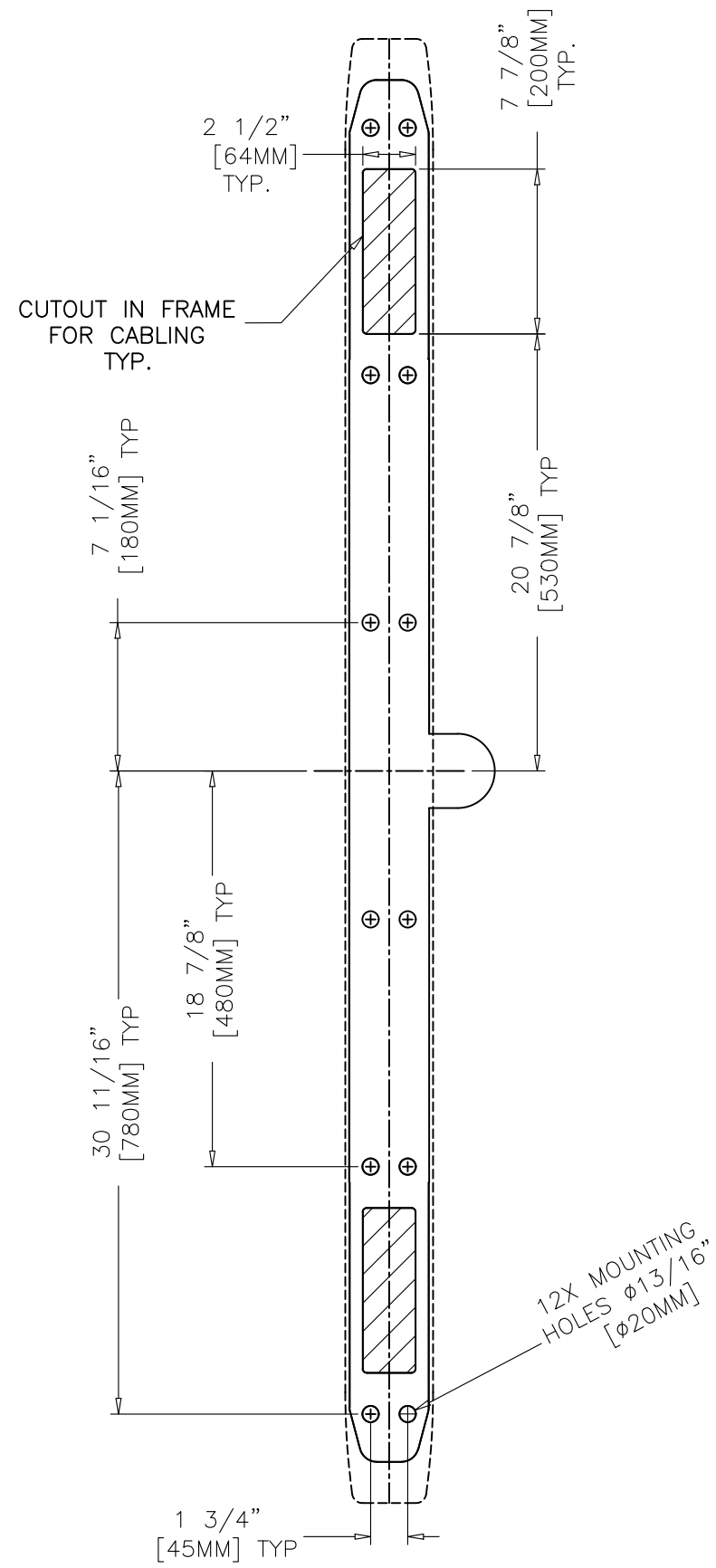

DETAIL A
LIFELINE SWING
FOOTPRINT

REV	DESCRIPTION	PAGE	DATE
C	SWING UPDATED TO 2.0	3 OF 3	8/7/20 AA
B	CHGD NOTE D & CONDUIT SIZE	3 OF 3	1/17/20 AA
A	CUTSHEET	3 OF 3	10/10/19 HM

REVISION LOG